

GLOBAL JOURNAL OF ENGINEERING SCIENCE AND RESEARCHES

COMPARATIVE ANALYSIS OF HARMONICS WITH AND WITHOUT SHUNT ACTIVE POWER FILTER

Vaishali Pardhi^{*1} & Dr.A K Kori²

^{*1}PG scholar HV JEC,jabalpur

²Professor ,JEC jabalpur

ABSTRACT

Electricity consumption had been increased so rapidly once in line with the development of the country to achieve its status as the industrial countries. The large consumption of electrical energy, one thing that plays an important role in a distribution system is the quality of electrical power itself. The distribution system will have many problems related to efficiency and functionality of electrical equipment. Therefore, the entire system does not operate efficiently due to the presence of harmonic in the distribution system. Among of them, one of the disorders that cause poor power quality is harmonic. This disturbance causes electrical equipment used to heat and cannot function properly. Thereby, the aim of this paper is to design and develop of a three phase shunt active power filter for harmonics reduction in industrial using MATLAB/SIMULINK[1,2].

Keywords- *Power System, Harmonic Distortion, Shunt Active Power Filter, Non-Linear Loads, Total Harmonic Distortion.*

I. INTRODUCTION

Power quality is important in the distribution system. To provide power supply with good quality is not easy because it depends on the type of load used. Phenomenon that causes an interruption in the electrical system such as overvoltage, voltage sags, voltage surges and harmonic [3]. Harmonic distortion problem has existed in the power system for a long time. it causes a wave of the line current and voltage in the power system to be distorted. In the past, discussions about the existence of harmonics have been discussed. However, at that time, the impact and influence of harmonic distortion is slightly lower than at present, where it only covers in the delta grounded w-ye connection of the transformer and also in some design of power transformer [4]. At present, the creation of modern equipment, especially electronic equipment and also the increased use of non-linear loads in industry has produced harmonic distortion, harmonic distortion in electrical systems became more serious because the use of electronic equipment are among the largest contributors to the formation of harmonic distortion. In recent years, with the increasing use of adjustable speed drives, arc furnace, controlled and uncontrolled rectifiers and other nonlinear loads, the power distribution system is polluted with harmonics. Such harmonics not only create more voltage and current stress but also are responsible for Electromagnetic interference, more losses, capacitor failure due to overloading, harmonic resonance, etc. Introduction of strict legislation such as IEEE519 [5] limits the maximum amount of harmonics (THD-Total Harmonic Distortion) that a supply system can tolerate for a particular type of load. Therefore, use of active or passive type filters is essential. To solve the current harmonic related problems, passive filters connected in several circuit configurations present a low cost solution. However passive filter implementations to filter out the current harmonics have the following disadvantages:

- Possibility of resonances with the source Impedance
- Supply impedance dependent system performance
- Fixed compensatio

II. INSTANTANEOUS ACTIVE AND REACTIVE POWER THEORY

The load currents are transformed from three phase frame reference *abc* into synchronous reference d-q coordinate by using parks transform in order to separate the harmonic contents from the fundamentals

$$\begin{bmatrix} i_{ld} \\ i_{lq} \\ i_{l0} \end{bmatrix} = \sqrt{\frac{2}{3}} \begin{bmatrix} \cos \theta & \cos(\theta - \frac{2\pi}{3}) & \cos(\theta + \frac{2\pi}{3}) \\ -\sin \theta & -\sin(\theta - \frac{2\pi}{3}) & -\sin(\theta + \frac{2\pi}{3}) \\ \frac{1}{\sqrt{2}} & \frac{1}{\sqrt{2}} & \frac{1}{\sqrt{2}} \end{bmatrix} \begin{bmatrix} i_{la} \\ i_{lb} \\ i_{lc} \end{bmatrix}$$

Where, θ is the angular position of the synchronous reference. This is a linear function of the fundamental. The harmonic reference current can be extracted from the load currents using a simple LPF with feed-forward effect. The currents in the synchronous reference can be decomposed into two terms as:

$$\begin{cases} i_{ld} = \bar{i}_{ld} + \tilde{i}_{ld} \\ i_{lq} = \bar{i}_{lq} + \tilde{i}_{lq} \end{cases}$$

Only the alternating terms -which are related to the harmonic contents - will be seen at the output of the extraction. The APF reference currents will be then, In order to find the APF currents in three phase system, the inverse Park transform can be follow:

$$\begin{bmatrix} i_{fa}^* \\ i_{fb}^* \\ i_{fc}^* \end{bmatrix} = \sqrt{\frac{2}{3}} \begin{bmatrix} \cos \theta & -\sin \theta \\ \cos(\theta - \frac{2\pi}{3}) & -\sin(\theta - \frac{2\pi}{3}) \\ \cos(\theta + \frac{2\pi}{3}) & \sin(\theta + \frac{2\pi}{3}) \end{bmatrix} \begin{bmatrix} i_{fd}^* \\ i_{fq}^* \end{bmatrix}$$

III. MODELLING OF SHUNT ACTIVE POWER FILTER

The simulation model of system without SAPF is shown in fig 4.1 and the simulation model of system with SAPF is shown in fig 3 which shunt active power filter (SAPF) is connected across the non linear load. The control of Shunt active power filter (SAPF) is divided in two parts. First part is used for the harmonic current extraction. There are instantaneous active and reactive power method (p-q method). Second part is used for the generation of gate pulse to control of voltage source inverter. Hysteresis Current Control Method is used.

Simulation model of system without sapf

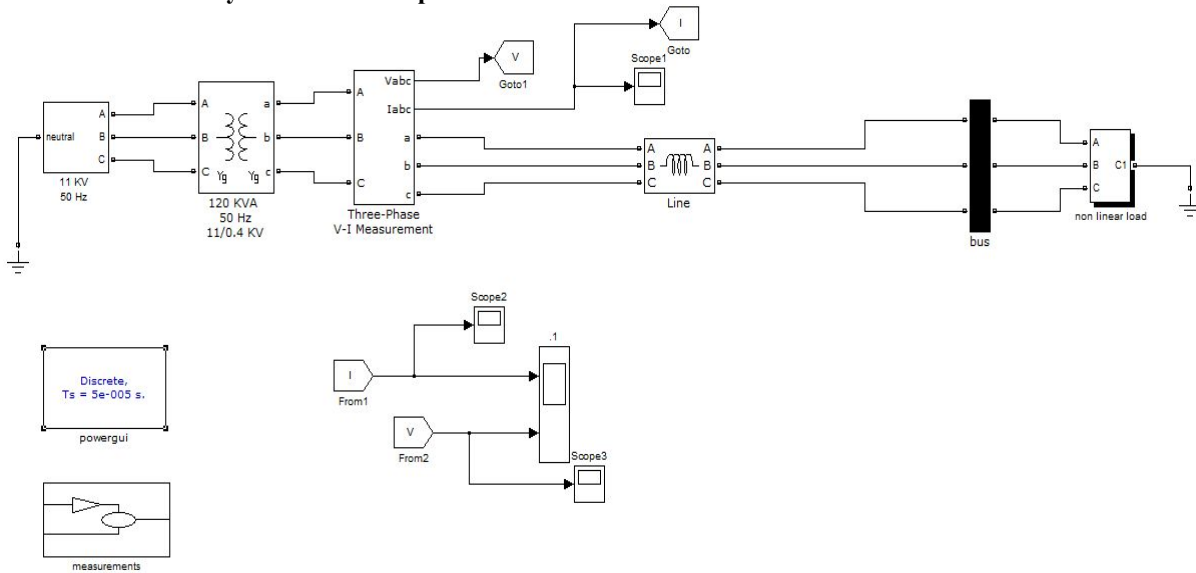

Fig.4. Simulation model of system without SAPF

Simulation Result

shows source current without shunt active filter. Due to the presence of the non linear load, so the current waveform is in distorted manner. The current is taken along the Y-axis and time is taken along the X-axis.

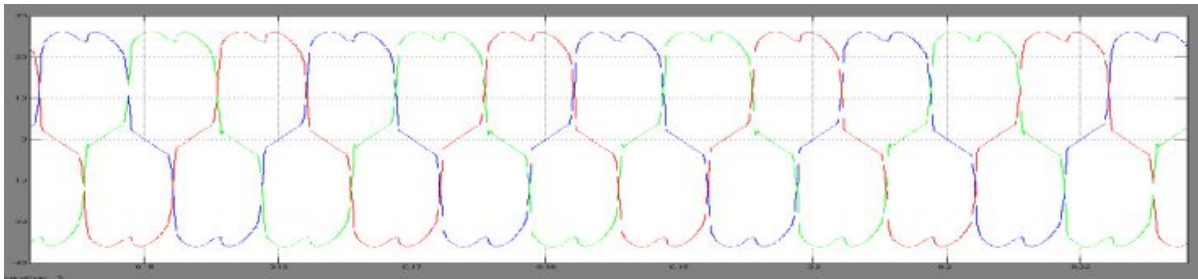

Fig.5 Voltage and current waveform without filter

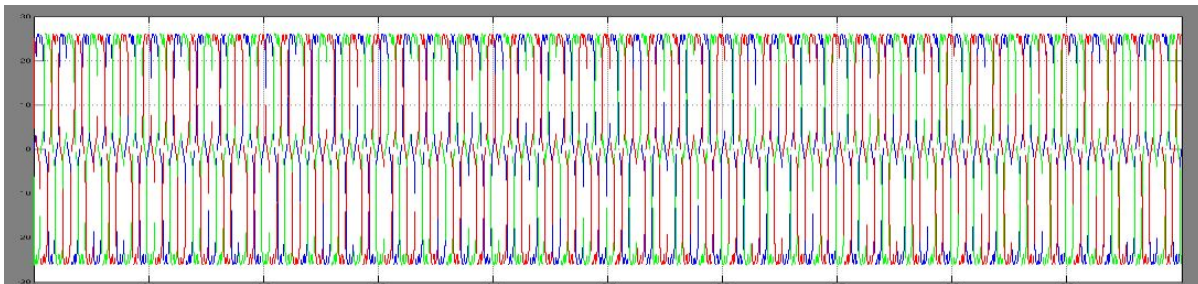

Fig.6 voltage and current waveform without filter

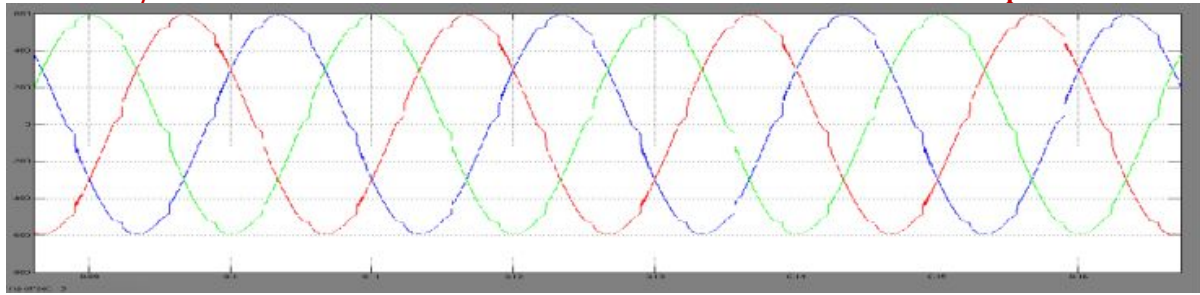

Fig 7. Voltage and Current Waveform without Filter

Simulation Model of System with Shunt Active Power Filter

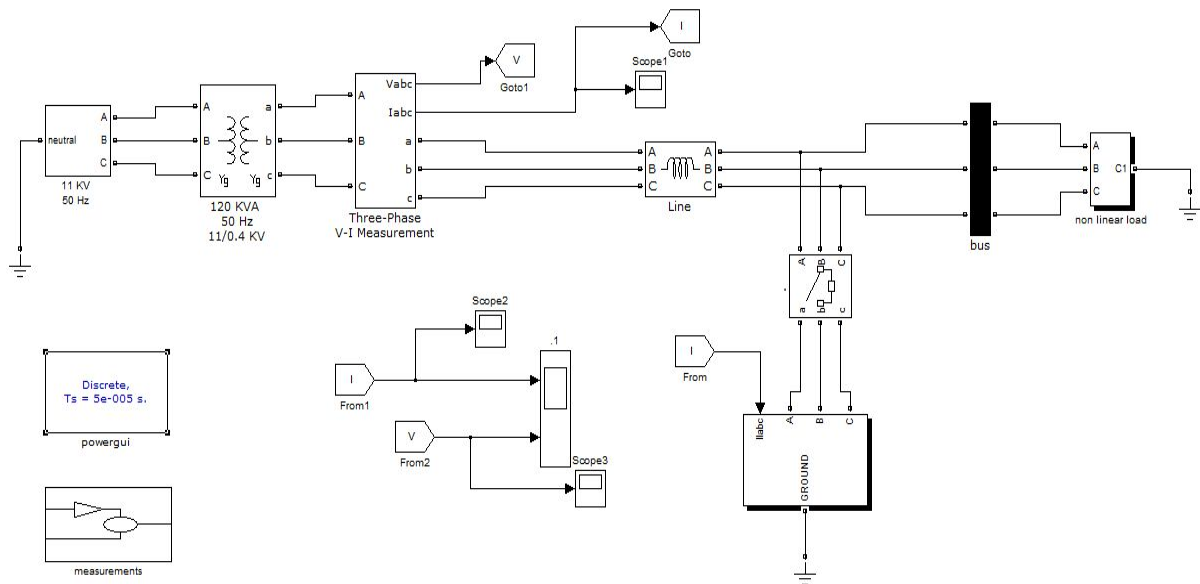

Fig.8 Simulation model of system with SAPF

Simulation Results

A number of simulations have been performed to check the working of the shunt active power filter under various non-linear loadings (w.r.t connection of the loads at the PCC) and nonideal supply. The analysis of the results show that the working of the active filter is very satisfied to compensate the harmonics and reactive power even under unbalanced and distorted conditions of distribution supply.

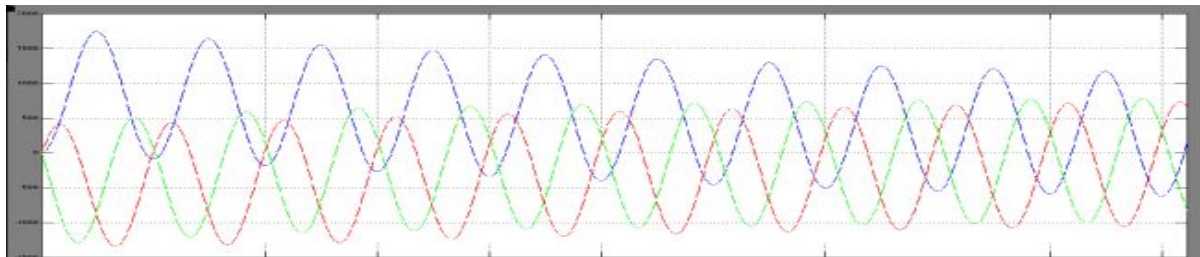

Fig.9 Voltage and current waveform with SAPF

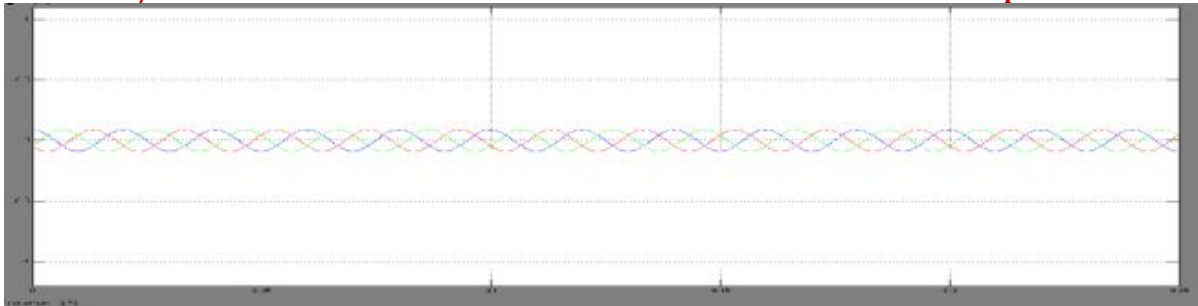

Fig.10 Voltage and current waveform with SAPF

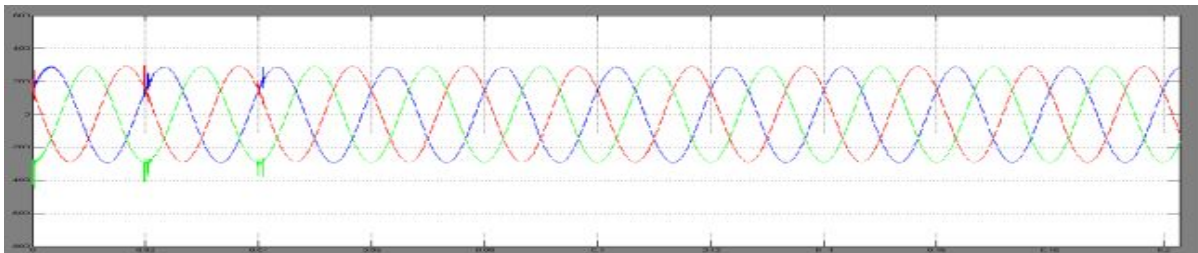
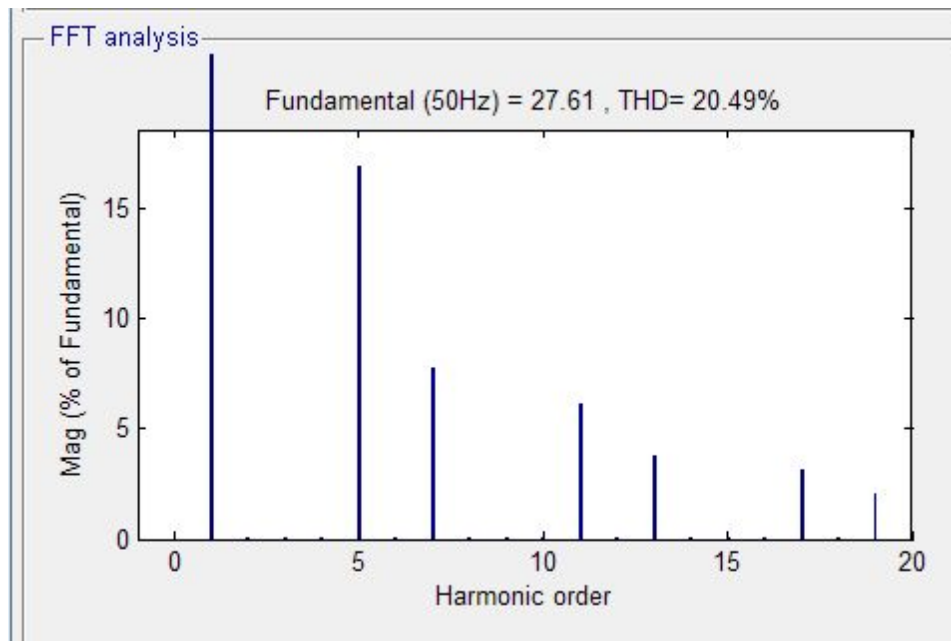

Fig.11 Voltage and current waveform with SAPF

IV. FFT ANALYSIS

The following figure shows the THD analysis of source current without SAF. THD is found to be 20.49% respectively due to nonlinear load which creates harmonics in the three phase system. In order to reduce



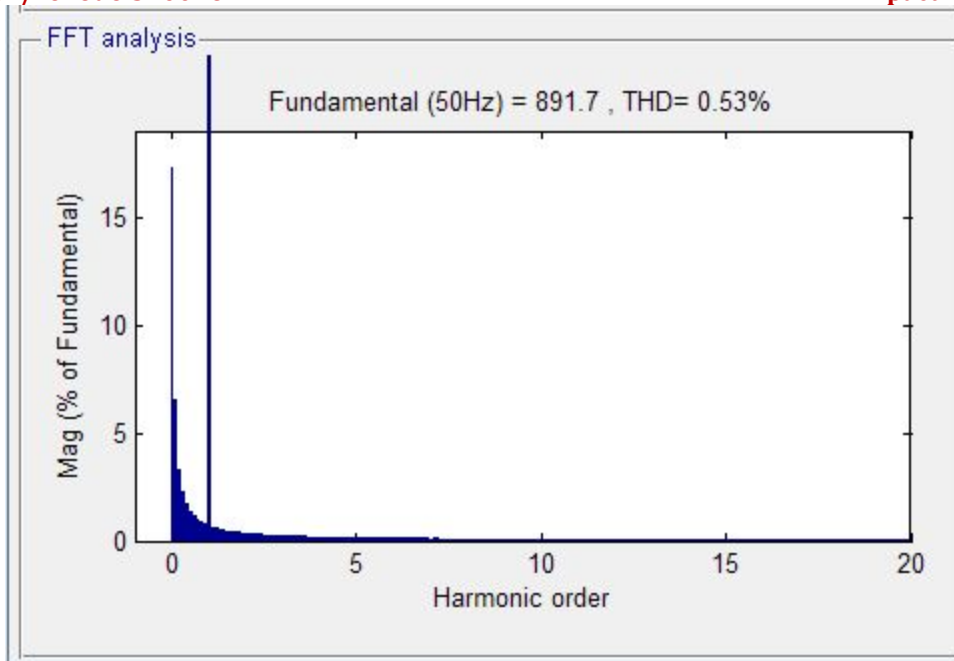

Table 1.Total Harmonics Distortion

THD IN SOURCE CURRENT BEFORE SHUNT ACTIVE FILTER	THD IN SOURCE CURRENT AFTER SHUNT ACTIVE FILTER
20.49%	0.53%

V. CONCLUSION

The three phase three wire shunt active filter with controller based on instantaneous active and reactive power (p-q) theory is simulated in MATLAB/SIMULINK to compensate the problems of the harmonics and reactive power which are encountered from power electronic non-linear loads. The performance of the shunt active power filter is investigated under different scenarios. It is investigated that the p-q theory based active filter manages to compensate the harmonics and reactive power of the power distribution network even under unbalanced and distorted supply voltages. The active power filter is able to reduce the THD in source current at a level well below the defined standards specified by power quality standards. The THD in source current after the active filtering is not exactly zero. It is because internal switching of the compensator itself generates some harmonics. In each of the case studied, the source current after the working of the active filter becomes perfectly sinusoidal, free from harmonics and in-phase with voltage of the main supply maintaining the unity power factor. In each simulation studied, multiple non-linear loads have been used to investigate the time response of the active filter. In each case it has noted that filter is successfully able to follow the reference currents with one power cycle with change in loads. It has been noted that if voltage unbalance or distortion or both are present in the system, the simple p-q theory didn't work well. It give rise the demand of the fundamental positive sequence voltage detector to extract the fundamental positive voltage form the unbalanced or distorted voltage. Once the fundamental positive sequence voltage is extracted, the theory worked very well. Even though the p-q theory has managed to compensate the harmonics and reactive power of the system and to produce the sinusoidal source current with unity power factor and free from harmonics.

VI. FUTURE WORK

The scope of the future work can be to look for the solution of the following points:

This work is based on three phase three wire system and the active filter does not work well if there is a zero sequence in the supply voltage. In future, a detailed analysis can be carried out for a 3 phase four wire filter in order to compensate the zero sequence present in the system. the APF for the compensation of harmonics and zero sequence.

REFERENCES

1. 978-1-4673-0455-9/12/\$31.00 ©2012 IEEE “Mitigation of Harmonics using Fuzzy Logic Controlled Shunt Active Power Filter with Different Membership Functions” By Instantaneous Power Theory, Suresh Mikkili and Anup Kumar Panda.
2. Akagi, H. 1994. Trends in active power line conditioners. *IEEE Trans. Power, Electron.*, vol.9, no.3, pp,263-268.2.Bhonsle, D.C., Zaveri, N.K., and Dr.Kelkar, R.B. 2008.Design and Simulation Of Single phase Shunt Active Power Filter for Harmonic mitigation in distribution system. *The International Conference on Electrical Engineering*.
3. Allmeling, J. A control structure for fast harmonics compensation in active filter *Electron.*, vol.19, no. 2, pp. 508-514, (Mar 2004).
4. Ali Ajami and Seyed Hossein Hosseini, 2006. “Implementation of a Active Filter”, *ECTI Transactions on Electrical Eng., Electronics, And Communications Vol.4, No.1*
5. Peng, F. Z., Akagi, H. and Nabae, A. A Novel Harmonics Power Filter. *IEEE Transaction of Electronics Specialists Conference. April 11-14. PESC '88 Record: IEEE. 1988. 1151-1159.*
6. T. Haddad. K. Joos. and A. Jaafari, "Performance Evaluation of Three Phase Three and Four Wire Active Filters", *Conference Record of the IEEE IAS Annual Meeting*, pp. 1016-1023, 1996.
7. F. Hamoudi., A. Chaghi., H. Amimeur., E. Merabet, "Sliding Mode Control of a Three-Phase Three-Leg Voltage Source Inverter Based Four-Wire Shunt Active Power Filter", *Journal of Electrical Systems*, no. 2, pp. 82-86, 2010